

## INSTALLATION AND USER MANUAL FOR



### IMPORTANT

**PLEASE READ THESE INSTRUCTIONS CAREFULLY PRIOR TO COMMENCING THE INSTALLATION OF THE UNIT**

The THERMAGLIDE door has been designed to provide years of trouble free use. The unit will perform efficiently only if it is installed and operated properly.

### READ THESE IMPORTANT SAFETY RULES FIRST

This equipment must be installed and used in accordance with these instructions. Failure to follow these instructions could result in damage to the integrity of the safety circuits.



CAUTION

**Two persons are required to install this product to ensure safe handling procedures.**

Do not wear rings, watches or loose clothing while installing or servicing the unit.

To avoid serious personal injury from entanglement, remove any ropes connected to the equipment prior to operating door.



DANGER

Installation and wiring must be in accordance with your local building and electrical regulations.

Any electrical work must be carried out by a suitably qualified person, if in doubt consult a qualified electrician.

Use only the mains lead supplied with the operator.

Connect the mains lead to an adjacent 13amp 3 pin switched socket.

The plug must be fitted with a 5 amp fuse.

**NOTE: For optimum electrical safety this unit should be connected to circuit protected by a R.C.D. (max 30 mA trip rating).**

This unit should not be installed in a damp or wet space.



DANGER

**Disconnect electric power to the control unit before making repairs or removing covers.**



CAUTION

Install the door control box (or any additional push buttons) in a location where the garage door is visible, but out of the reach of children. Do not allow children to operate push button(s) or remote control(s). Serious personal injury from a closing garage door may result from misuse of the operator.

**CAUTION: Activate unit only when the door is in full view, free of obstructions and operator is properly adjusted. No one should enter or leave the garage while the door is in motion. Do not allow children to play near the door.**



CAUTION

**IMPORTANT: Fix the caution label supplied to the rear of the garage door as a reminder of safe operating procedures.**

### NOTE TO INSTALLER

**PLEASE ENSURE THIS MANUAL REMAINS WITH THE END USER AS IT CONTAINS IMPORTANT SAFETY AND WARRANTY INFORMATION**

2

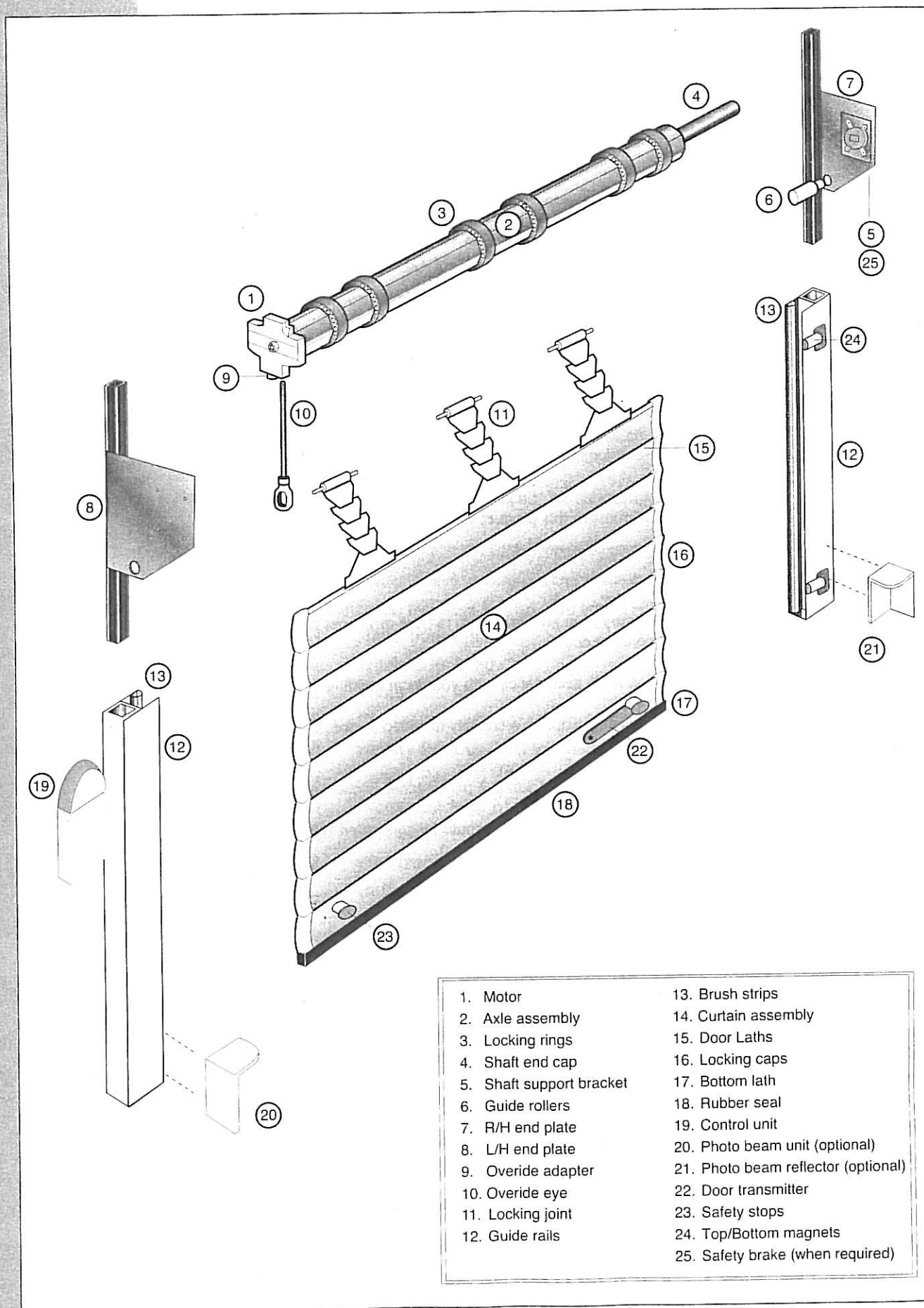

## COMPONENT CHECK:

Unpack and check that all components are present.

- 1** Curtain assembly (inc. set of locking joints)
- 2** Axle assembly (pre-fitted with motor, locking rings and shaft end cap)
- 3** 1 pair of guide rails (pre-fitted with brush strips and safety edge magnets)
- 4** Accessory pack comprising:
  - 1 pair of end plates (pre-fitted with rollers)
  - 1 motor override eye and manual winding handle
  - 1 shaft support bracket
  - 1 fittings pack
  - 1 pair safety stops and fixings
- 5** Control system comprised of:-
  - Control unit/radio receiver
  - Photo cell unit (optional)
  - Mains lead
  - Remote hand transmitter
  - Photo cell reflector and mounting bracket set (optional)
  - Safety edge transmitter

} Pre-wired and temporarily attached to axle assembly for R.H. Motor installation as standard

## 1

### PRE-INSTALLATION CHECK:

#### IMPORTANT NOTE

In case of power failure a manual override system is fitted as standard but this can only be operated from inside the garage.

If the garage has no service entrance door then an EXTERIOR RELEASE KIT MUST be fitted to allow manual operation of the garage door from outside.

(See back page for order details).

- 1** Check that the door size and colour correspond with that which was ordered.
- 2** Structural condition of opening
 

**ENSURE THE AREA AROUND THE OPENING IS STRONG ENOUGH TO SUPPORT THE DOOR**

The surface where the door is to be fitted must be flush and reasonably smooth. Small irregularities in the brickwork will be acceptable. The lintel must not protrude backwards or forwards from the brick piers. Should the lintel protrude backwards or forwards from the brick piers this will require special instructions, please consult your *Thermaglide* dealer.
- 3** Fitting notes
  - 3.1 It is recommended that 2 people are available for fitting all door sizes.
  - 3.2 **The door must be fitted square and level, irrespective of the shape of the opening. On no account should any compensation be made to suit an irregular opening.**
  - 3.3 Ensure all necessary tools are to hand before starting.
  - 3.4 The door package and its contents should be checked for obvious damage before removal of the wrapping.

**IF THERE IS ANY DAMAGE YOUR SUPPLIER SHOULD BE CONTACTED IMMEDIATELY.**
- 4** Ensure there is a suitable 13amp 3 pin switched socket adjacent to where the control box is to be fitted. (see *safety rules*)
- 5** Ensure all tools and door components are gathered together inside the garage prior to starting the installation.

#### Tools required:-

2 stepladders	3.8 drill bit
Spirit level	7.0 drill bit
Steel tape	13.0 drill bit
Power drill	Hacksaw
10mm A/F spanner	Suitable wall plugs (not supplied) <i>see note A</i>
Slot screwdriver	Small electrical screwdriver
Pozi screwdriver	3mm A/F Allen key

## 2

## CHECK HEADROOM

The headroom is the clear vertical height required between the top of the guide rails and any obstruction above the shutter (see Figs 1 and 2).

This space is required to house the door roll and for doors up to 9.0 sq. metres a headroom of 270mm is required. For doors over 9.0 sq. metres this increases to 300mm.

**Limited Head room**

If insufficient headroom is available the door can still be fitted (see your survey sheet) but the shorter guide rails will give a corresponding reduction in **door opening height** (see Fig 3).

**NOTE:** Ensure that the headroom above the guides is clear of any obstructions (especially small protrusions or nail heads) which could cause damage to the door roll during installation/operation.

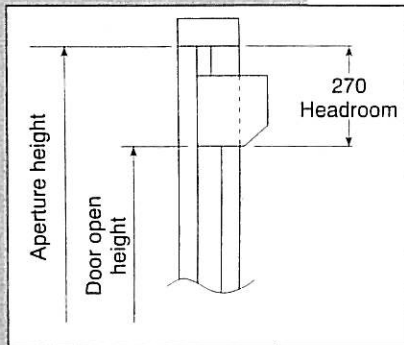

Fig 1 Headroom within aperture

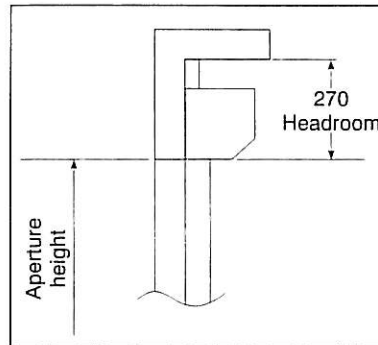

Fig 2 Headroom behind aperture

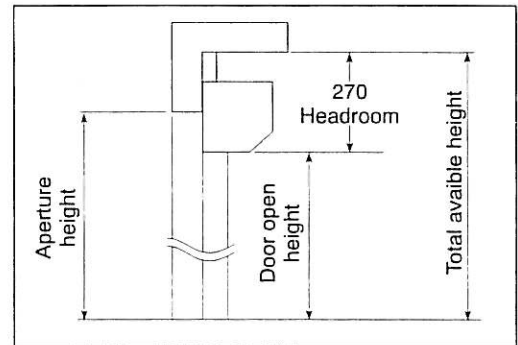

Fig 3 Limited headroom

## 3

## PREPARING THE GUIDE RAILS

**3.1** For fitting **WITHIN** the aperture.**3.1.1** Check guide rail length

Check that guide rails have been supplied to the correct length as per your survey sheet/order. The correct length is aperture height less 270mm (see Fig 1).

**3.1.2** Drill fixing holes

Drill holes through 7.0 diameter and counter drill 13.0 diameter as shown in Fig 4. Three holes per rail are required, positioned as shown in Fig 5.

**NB.** Position holes for best fixing to brickwork.

**3.2** For fitting **BEHIND** the aperture**3.2.1** Check guide rail length

Check that guide rails have been supplied to the correct length as per your survey sheet/order.

- Where headroom of 270mm or more is available guide rail length equals **aperture height** (see Fig 6).
- Where only limited headroom is available guide rail length equals total available height less 270mm. (see Fig 7).

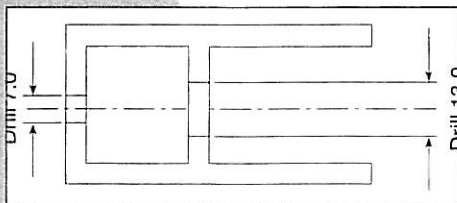

Fig 4

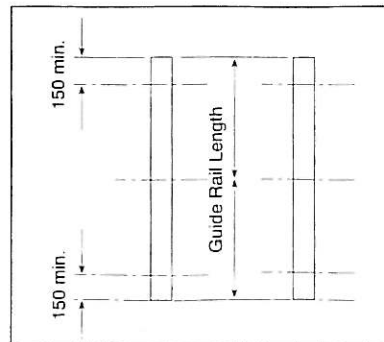

Fig 5

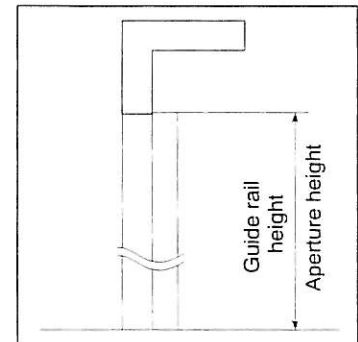

Fig 6

### 3.2.2 Drill fixing holes

Drill holes through 7.0 diameter and counter drill 13.0 diameter as shown in Fig 8.

Three holes per rail are required as shown in Fig 9.

NB position holes for best fixing to brickwork.

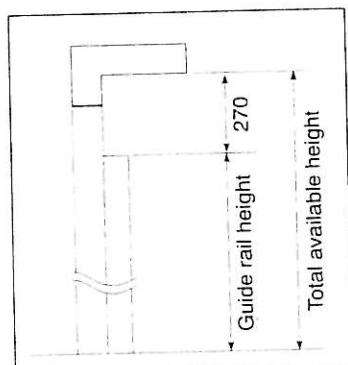

Fig 7

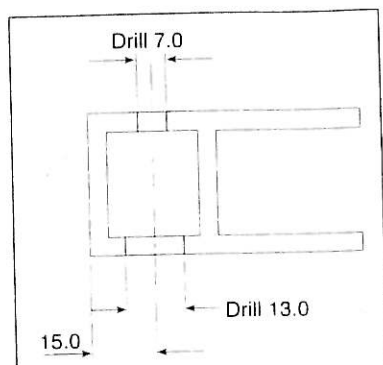

Fig 8

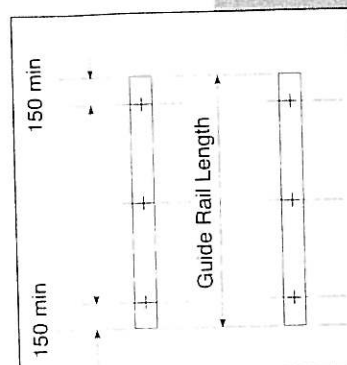

Fig 9

## 4 ASSEMBLE FRAME

### 4.1 L/H or R/H motor

The motor and control unit can be mounted on either the L/H side or R/H side. Decide which side is best suited for your installation and proceed accordingly.

(Fig 11 shows assembly for RH motor mounting).

**NOTE ALL** units are supplied pre-wired for **RH** motor mounting as standard (see page 9)

All doors that have the potential to exert an out of balance force of in excess of 200N are fitted with a safety break (this is approximately doors over 9' x 7')

- This device is factory fitted to the left hand end plate, if you want to change the hand of the motor this should be fitted to the opposite plate.
- If you do move the safety break ensure that the writing is at the top of the plate otherwise the unit will activate under normal running conditions.
- It is important that the head plates are securely fixed to the wall.

### 4.2 Fit end plates

Lay the axle assembly on the ground, parallel with and just inside the garage opening. Ensure the motor is situated at the correct end for your installation and that the motor limit adjusters are at the top/bottom (see Fig 10).

Fix the end plate to the motor using two M6 x 25 c'sunk screws and M6 Nyloc nuts provided. See Fig 11.

Fix SHAFT to end plate by aligning hole in shaft with hole in 'U' bracket and using the M6 x 35 Hex head bolt and M6 Nyloc nut provided (see Fig 12).

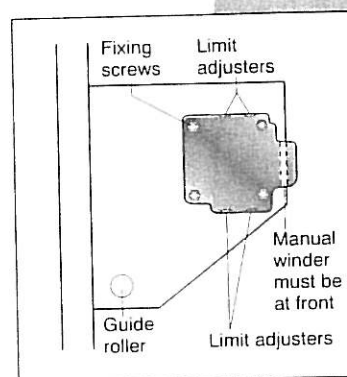

Fig 10

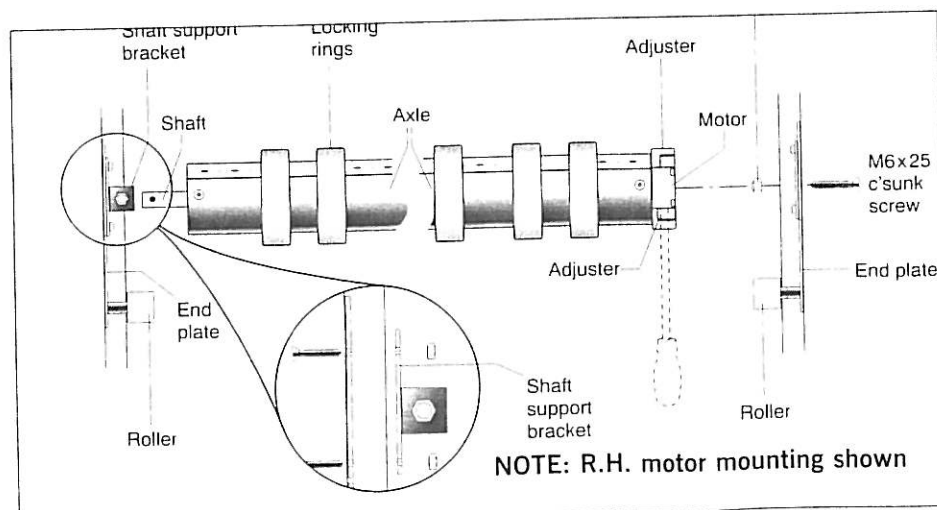

Fig 11

Fix the shaft support bracket to the other end plate using 4 off M6 x 25 c'sunk screws and M6 Nyloc nuts provided. Ensure orientation of the bracket is as shown in Fig 12.

#### 4.3 Fit guide rails

Select R/H guide rail and slide fully onto the bottom square tube spigot projecting from the R/H end plate. Repeat for the L/H guide rail as shown in Fig 13.

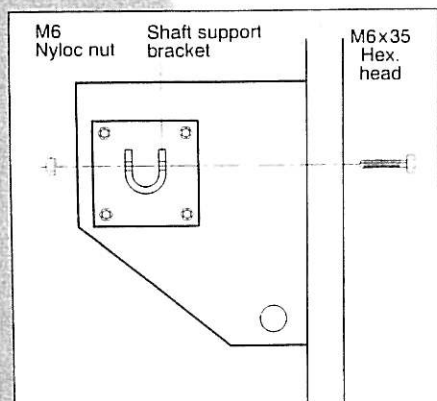

Fig 12

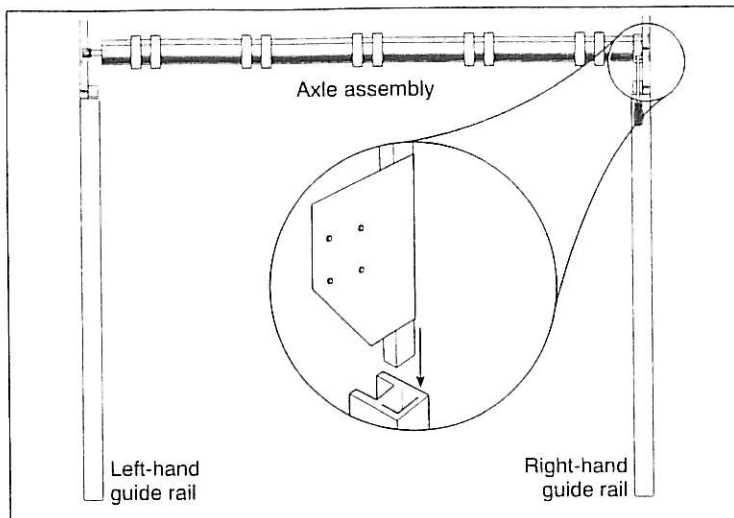

Fig 13

## 5 INSTALL FRAME

You will have drilled your guide rails (Section 3) for fitting either:-

- a Within the aperture    b Behind the aperture

Please proceed accordingly. (SAFETY NOTE: 2 people required)

#### 5.1 Fitting within aperture

For installation **within** the aperture we strongly recommend the use of a Fascia plate as this covers and protects the door curtain roll

##### 5.1.1 Fit fascia plate as per the instructions provided with that item.

##### 5.1.2 Lift the frame assembly into position and align with the front of the aperture.

Ensure the guide rails are VERTICAL (in both directions) are parallel to each other, at the same height and the correct distance apart.

**NB:** Some width adjustment is available on the sliding shaft end of the axle, the correct distance is shown in Fig 14.

Ensure the axle assembly is horizontal by using a spirit level.

##### 5.1.3 Once the frame is correctly positioned, mark and drill for fixings.

Use 3 per side of the No. 12 x 3" self tapping screws provided using suitable wall plugs (see Note A).

##### 5.1.4 When the guide rails are securely fixed, double check that they are vertical, parallel and correct distance apart and that the axle assembly is level.

##### 5.1.5 Fix end plates to the wall by drilling a hole 7.0 diameter through the plate in a position to suit the brickwork. Drill the brickwork and fix with one No. 12 x 3" screw (provided) in each end plate (see Note A).

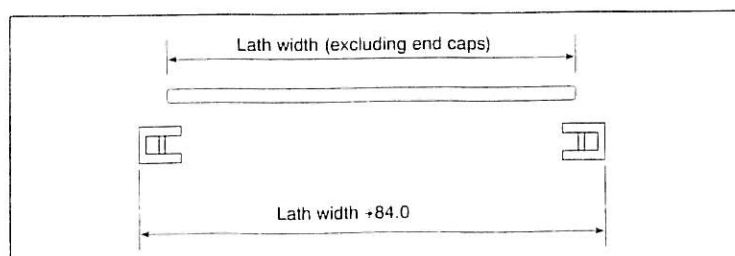

Fig 14

## 5.2 Fitting behind aperture

Lift the frame assembly into position and align centrally with the aperture. Ensure the guide rails are vertical (in both directions) and are parallel to each other, at the same height and the correct distance apart.

**NOTE:** Some width adjustment is available on the sliding shaft end of the axle. The correct distance apart is shown in Fig 14.

Ensure axle assembly is horizontal by using a spirit level.

- 5.2.1 Once the frame is correctly positioned, mark and drill for fixings. Use 3 per side of the No. 12 x 3" self tapping screws provided and suitable wall plugs (see *Note A*).
- 5.2.2 When guide rails are securely fixed, double check for vertical, parallel and correct spacing and that the axle is level.
- 5.2.3 Fix end plates to lintel wall by drilling a hole (7.0 diameter) through the square tube projecting above the end plate, position to suit brickwork. Drill the brickwork and fix with one No.12 x 3" screw (provided) in each end plate.

**NOTE:** Once the frame is fully fitted and checked, use the plastic plugs supplied to cover the fixing holes in the guide rails to give a 'fully finished' effect.

## 6 INSTALLING THE CURTAIN ASSEMBLY

- 6.1 Carefully unwrap and remove the **electrical control system** from the axle, where it is attached only for transportation purposes. Temporarily secure it to one side, away from the axle and frame assembly.
- 6.2 Carefully position the curtain assembly in the door aperture, below the axle as shown in Fig. 15. Slit the packaging to gain access to the curtain but leave some packaging to protect the curtain.

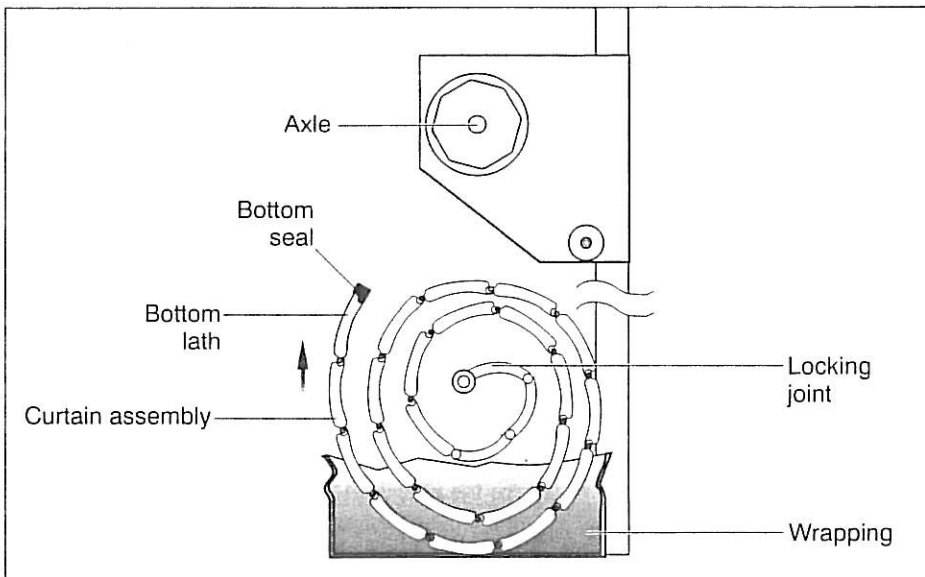

Fig 15

### 6.3 SAFETY NOTE: Two people are required for this procedure to ensure safe handling.

- 6.3.1 It is essential to place sections of bubble wrap or card over the axle to prevent marking the curtain as it is installed.
- 6.3.2 Using 2 people carefully lift the curtain assembly up level with the axle. Practice has shown that it is best to place one hand on the axle, keeping that arm straight, and support the curtain roll on that shoulder (see Fig 16).
- 6.3.3 Feed the bottom lath over the top of the axle and down between the guide rails (see Fig 17) taking care not to scuff the curtain assembly. Proceed until the full curtain has been fed over the axle and the bottom lath reaches the floor.

**NOTE:** Do not let the curtain 'free fall' over the axle as this will result in damage to the curtain.

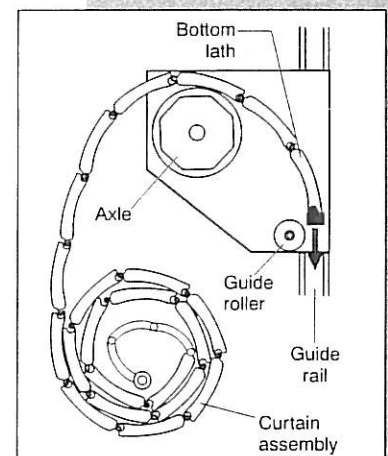

Fig 17

**Thermaglide®**

- 6.4 Now fix the safety stops with the fixings supplied (M6 x 40 c'sunk pozi bolts) to the pre fitted nut sets on the bottom rail

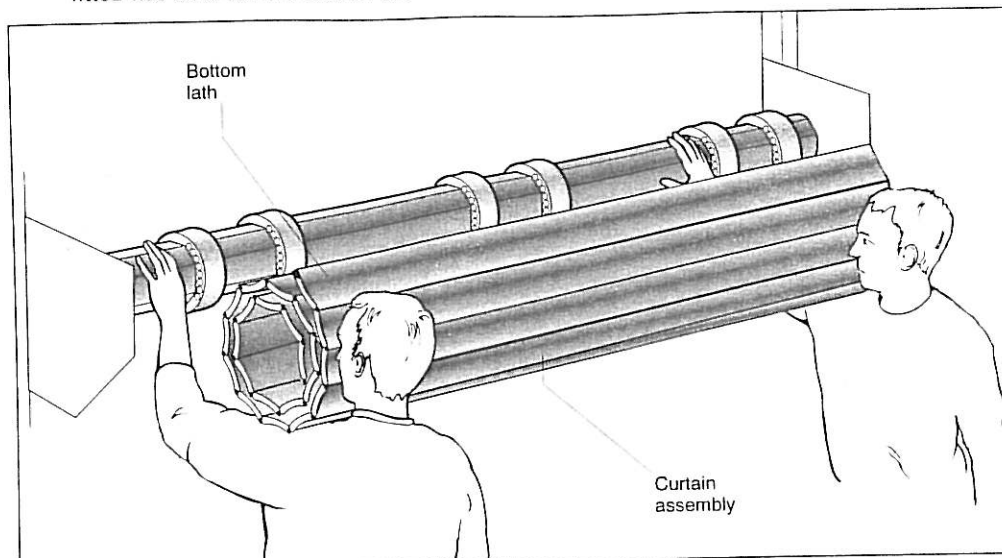

Fig 16

## 7 CONNECT THE ELECTRICS

### 7.1 FIT THE MOTOR OVERRIDE

Attach the motor override EYE fitting to the motor as shown in Fig 22. Using 3mm A/F Allen key.

### 7.2 POSITION THE AXLE

Use the motor override to rotate the axle shaft. Rotate the axle until the locking joint attachment holes are positioned as shown in Fig 23.

- 7.3 There are a pair of locking rings positioned on the shaft for each locking joint, the number of locking rings will vary according to curtain width. Clamp the outermost rings to the shaft approx. 150mm in from each end and equally space the other pairs as shown in fig. 24.

Slide each locking joint along the top lath and engage the fastening pin into the appropriate hole in the respective clamped locking ring. (Four holes are provided in the rings so that shaft position is not critical).

Slide the loose locking ring to engage the other end of the fastening pin and secure the loose locking ring to the shaft using the clamping screw. Repeat this for each locking joint. (see Fig 24).

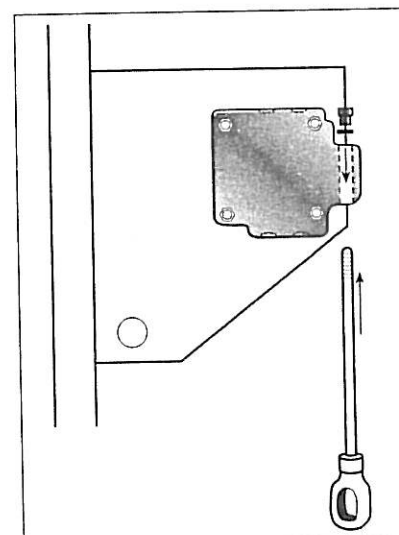

Fig 22

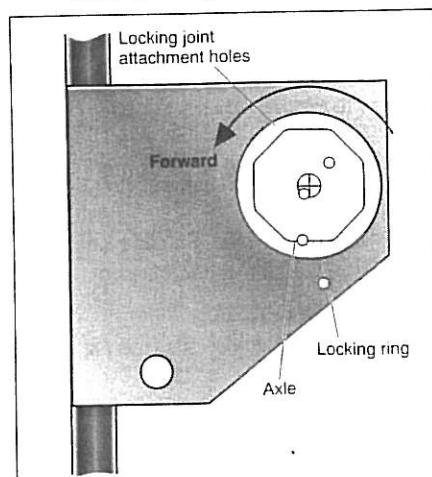

Fig 23

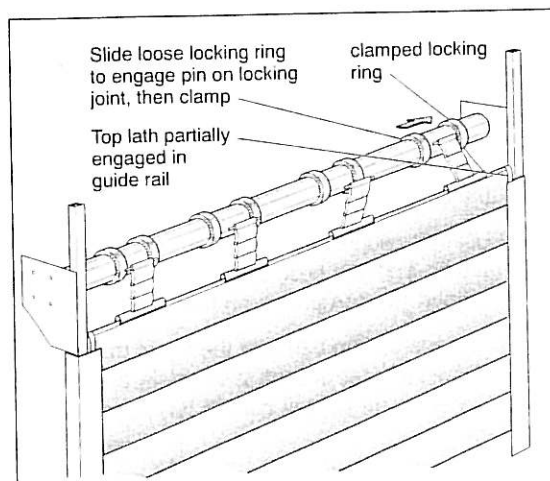

Fig 24



## 8

## ATTACH THE CURTAIN

8.1.1 The electric motor, control box and mains lead are pre-wired together and have been temporarily secured to one side. Release them from this temporary fixing.

8.2 Preparing The Thermaglride Remote Control For Installation

- Remove the light cover from the top of the unit by pressing in at the bottom on both sides and lifting it away from the blue back.
- The Blue front cover of the unit can now be removed by loosening the 4 screws and lifting it away from the rest of the unit.
- Push the LED from the front side of the cover and it will come away from the lid.
- Unplug the front cover buttons connector lead from the circuit board. Place the lid to one side.
- Take the two aerials out from the accessory pack and attach them to the unit (See entry point and terminals in top left hand corner). Make sure that the aerials are not touching and that they point in opposite directions (E.g. one up and one down).

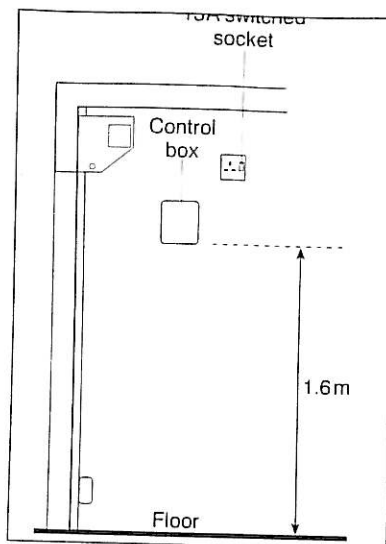

Fig 18

8.3 Fixing The Thermaglride Remote Control to the Wall

- Inside the accessory pack you will find the fixings for attaching the unit to the wall.
- Make sure that the unit is mounted onto internal brickwork and is firmly fixed.
- The unit must be installed with the courtesy light at the top. Hold the unit against the wall at a height of at least 1.6 meters and mark where the screw fixings should be. (fig 18)
- Take the unit away and drill the holes. Fix unit to the wall. Remove the cardboard cover from the light bulb.

**THIS MUST BE FITTED INSIDE THE GARAGE AS NOT IP RATED**

8.4 Plug power lead into 13A socket but **DO NOT SWITCH ON** at this stage.

## 9

## SETTING CURTAIN OPEN AND CLOSE POSITION

9.1 SETTING OPEN POSITION

9.1.1 Ensure power is turned OFF.

9.1.2 Remove the protective cap from the head of the motor. (see Fig 25)

9.1.3 Fully depress both limit switch buttons. (see Fig 25). They will automatically lock in the down position.

9.1.4 Turn power ON and operate the START button. Ensure the curtain is moving in the OPEN direction. **IF THIS IS NOT CORRECT STOP IMMEDIATELY.**

Switch off power and interchange the motor wires at terminals L1, L2 (see Fig 30). Switch power back on and operate start button again, curtain should move in correct OPEN direction.

9.1.5 Identify the OPEN limit switch button on the motor (see Fig 25 for RH or LH mounted motor).

9.1.6 When the curtain approaches the fully open position operate the STOP button to hold the curtain in position.

9.1.7 Use the Motor override handle to move the curtain to the correct OPEN position. **IMPORTANT** see Fig 26 for correct OPEN position.

9.1.8 Set the OPEN limit switch by depressing and releasing the limit switch button.

9.2 SETTING CLOSE POSITION

9.2.1 Press the START button so curtain moves downwards.

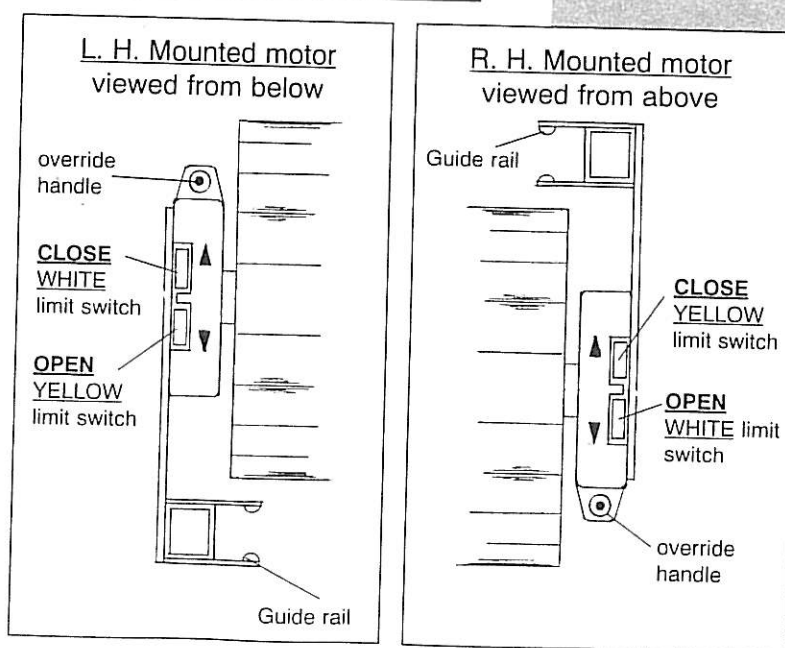

Fig 25

- 9.2.2 Identify the CLOSE limit switch on the motor (see Fig 25).  
 9.2.3 When the curtain approaches the fully closed position operate the STOP button.  
 9.2.4 Use the Motor override handle to move the curtain to the correct CLOSED position.  
**IMPORTANT** see Fig 27 and Fig 28 in section 10 for correct CLOSE position.

- 9.2.5 Set the CLOSE limit switch by depressing and releasing the limit switch button.

### 9.3 CHECK SETTINGS

Operate the door a number of times to ensure the limits are correctly set. In particular the CLOSED 'LOCKED' position (section 10).

- 9.4 Reset the protective cap on the limit switches. (Take care not to depress the limit switch buttons.)

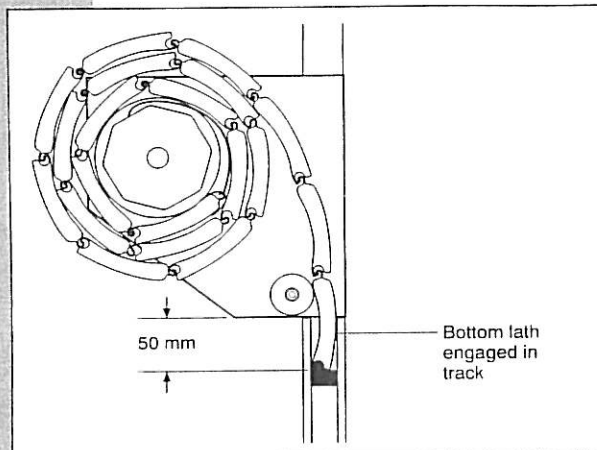

Fig 26 Fully open position

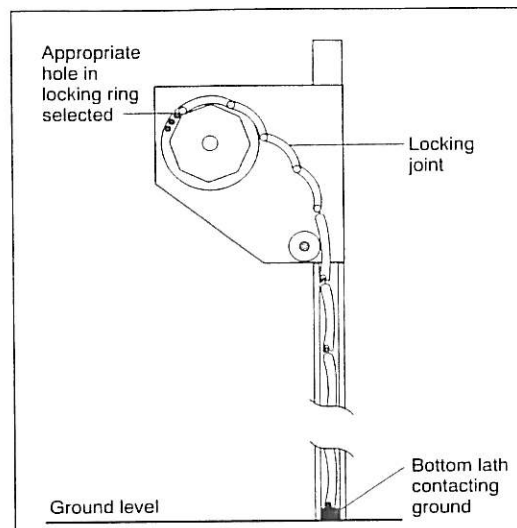

Fig 27 Fully closed position

## 10

### SETTING THE 'LOCKED' POSITION

In order that the locking joints operate effectively, the position of the shaft in the closed position needs to be finely adjusted. Use the Manual override to move the curtain downwards until the bottom lath is pushed firmly on the ground and the top lath is pushed hard against the head. The locking joints should be sprung into the locked position. (Fig 28). Do not adjust past this position as this will impose excessive loads on the mechanism.

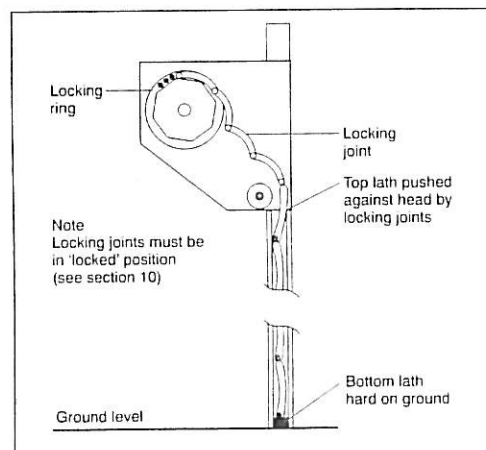

Fig 28

## 11

### ELECTRICAL CONTROL CIRCUIT DIAGRAM

#### 11.1 Wiring The Thermaglide Remote Control

The unit will be pre wired as follows. This will be done at Steel Line in accordance with how the door has been ordered. If the motor side needs to be altered switch the wires between T8 & T9.

Please Note: Any wires that come into the unit from above must incorporate a drip loop. The pre-wired 13-amp plug should be plugged directly into a standard household socket.

#### 11.2 Attaching The Safety Edge Transmitter To The Door

Plug in the two pin connector from the safety edge to the door transmitter.

Fix the door transmitter to the pre fitted rigid back with the screws provided.

Once the Safety edge transmitter is fitted to the door the safety edge will be fully operational, it is strongly advised that the door be run through one full open and close cycle and the safety edge tested prior to the completion of the installation.

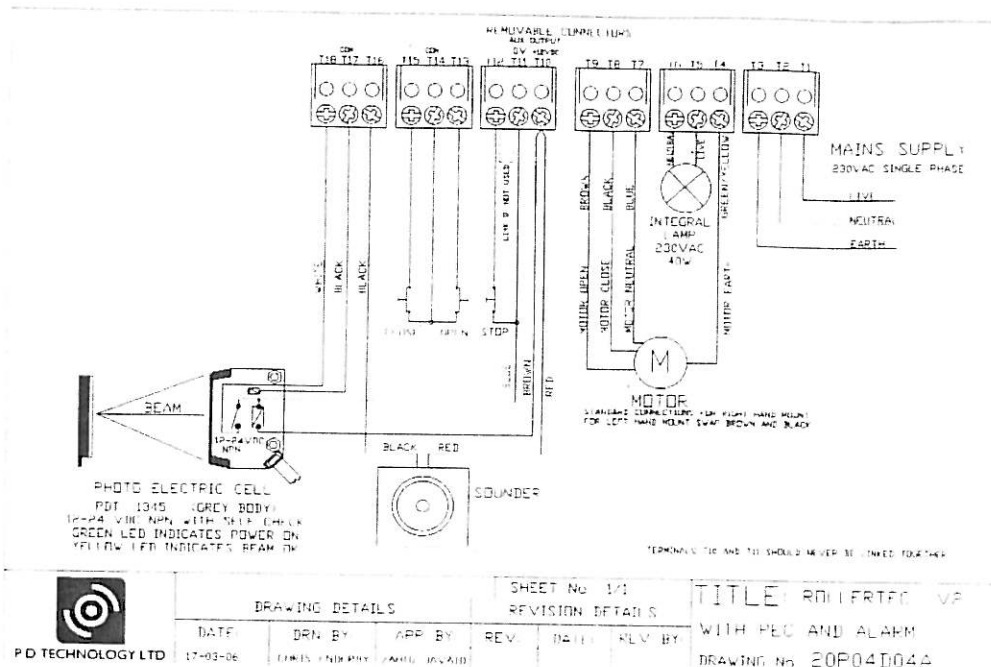

- |   |  |
|---|--|
| T1 Mains Live (Brown/Red)                         | T10 Alarm Wire (Red)   |
| T2 Mains Neutral (Blue/Black)                     | T11 } Link Between T12 & T11 (Required if not using an emergency stop) |
| T3 Mains Earth (Yellow & Green)                   | T12 }  |
| T4 Motor Earth (Yellow & Green)                   | T13 External Switch (Open)   |
| T5 Courtesy Light Live                            | T14 External Switch (Common)   |
| T6 Courtesy Light Neutral                         | T15 External Switch (Close)  |
| T7 Motor Neutral (Blue)                           | T16 Alarm Wire (Black Wire)  |
| T8 Motor Close (Black R/H Motor, Brown L/H Motor) | T17 }  |
| T9 Motor Open (Brown R/H Motor, Black L/H Motor)  | T18 }  |

### 11.3 The Alarm

- The alarm is supplied pre-wired into the Thermaglide Remote Control. The red wire is wired into T10 and the black wired is wired into T16.
- The alarm sounds for five minutes if the garage door is lifted manually above the bottom magnet.
- To set the alarm you must have the door at the fully closed position and press the stop and the down button on the hand set simultaneously for 5 seconds, on releasing the buttons the wall mounted LED will flash RED, AMBER, GREEN in fast succession.
- To reset the alarm once activated you should press the top green button on one of the hand sets to start the door moving in the up direction.
- Once the alarm has been turned off it takes 60 seconds to reset itself before it is able to re-activate (E.g. If the door is immediately closed after the alarm has been turned off, the alarm would not sound if the door was re-lifted above the bottom magnet within 60 seconds of its last activation).

### 11.4 Attaching The Photo Electric Cell (Optional)

#### This is in addition to the Safety Edge

Take the photo-electric cell, the reflector, the 2 grey plastic fixing brackets and the fixing screws from the box. Measure 200mm up the guide from the floor. This is the height that the photo-electric cell should be mounted at. Attach the hardwired part to the same side of the guide that the wall unit is on for easy wire connection and the reflector on the other. Wire the photo-electric cell in to the wall unit as follows.

- Brown** T10
- Blue** T11 leave the link to T12
- Black** T17
- White** T18 remove the link between T17 & T18
- DIP 1** (Dip switch 1 = OFF)

Once the photo cell has been connected correctly a green power LED will illuminate on the top of the unit. To ensure that the photo-electric cell is aligned take a plumb line from the hard wired side to the reflector to make sure they can see each other. Once they are aligned the photo-electric cell will have an orange LED illuminated on the top. The door should now operate correctly.

## 12 OPERATION

**12.1** The door can be operated using the directional controls on the front panel of the Thermaglide remote unit, the handset or other optional controls (wire less key pad, Key switch etc).  
It is not possible to connect a bell push to the door as the remote unit does not work via an impulse mechanism an up down switch is required.

**12.2** The door will under normal circumstances work automatically (i.e. any of the switching mechanisms will result in the full travel of the door).

The LED on the remote control unit will show the following status under normal conditions:-

- Green Door fully open
- Flashing Green Door opening
- Amber Door stopped in mid position
- Red Door fully closed
- Flashing Red Door closing

If the travel of the door has been interrupted buy either an obstruction or been left between the top and bottom limit the door will only open automatically and the close sequence would only be possible on a hold to run basis.

Returning the door to the fully open position will allow a fully operational status to be resumed if the above situation has arisen.

**12.3** The courtesy light will switch on for 3 minutes whenever the door is operated and will turn off automatically.

**12.4** In the event of the door not operating refer to the trouble shooting guide.

## 13 ADDING TRANSMITTERS

Transmitters can be added using the on board Dipswitches or with a transmitter that is already loaded onto the control unit.

**STEEL LINE STRONGLY ADVISE THAT ONLY QUALIFIED INSTALLERS USE THE DIPSWITCH METHOD AND ONLY IN THE EVENT OF THE LOSS OF ALL OTHER TRANSMITTERS**

**ONLY TRANSMITTERS BOUGHT FROM STEEL LINE WILL BE COMPATABLE WITH THE THERMAGLIDE REMOTE CONTROLE**

**Selecting & Deleting Channels on the Thermaglide Transmitter**

**IF THERE IS ONLY 1 DOOR ON SITE YOU DO NOT NEED TO ADD ADDITIONAL CHANNELS**

The Thermaglide transmitter has been designed to control up to 8 separate roller shutters. The key fob has 8 separate channels and gives the user individual open, stop and close buttons for each shutter.

The 8 different channels are indicated via the small LED in the top right hand corner of the transmitter and are as follows:

Channel	LED Sequence
ONE	1 X RED FLASH
TWO	2 X RED FLASH
THREE	3 X RED FLASH
FOUR	4 X RED FLASH
FIVE	5 X RED FLASH
SIX	6 X RED FLASH
SEVEN	7 X RED FLASH
EIGHT	8 X RED FLASH

**Selecting and Commissioning a Channel**

1. Press and hold down the grey button on an existing transmitter and release the button when the LED on the key fob starts to flash Yellow.

2. Whilst the LED is flashing yellow press the grey button again to begin scrolling through the channels. Each press of the grey button will select the next channel in the sequence. Stop when you reach the channel you require.

3. To commission the channel press the top green button once, the LED on the wall mounted unit will flash green and then yellow, press the top green button again the LED will flash green and then yellow. Pressing the top green button a third time will display the commissioned channel on the LED. The LED will then go out.

### Deleting a Channel

1. Press the grey button consecutively until the channel you require is displayed on the LED in the top right hand corner.
2. Wait for 10 seconds
3. Press and hold down the grey button until the LED on the transmitter starts to flash yellow, then release.
4. Press and hold down the RED button, only release the RED button when the LED is green, this takes about 15 seconds.
5. The LED will flash RED, YELLOW, GREEN four times to confirm that the channel was deleted successfully.

### Existing Transmitter Method

1. Press and hold down the Grey button on a transmitter that is already loaded onto the control unit. The lid-mounted signal LED will flash YELLOW slowly; keep the button held down until it flashes YELLOW quickly.
2. Release the Grey Button.  
*The lid-mounted signal LED will continue to flash YELLOW quickly.*
3. Press the top green button on the same transmitter once.  
*The flashing LED will change from flashing YELLOW to flashing GREEN.*
4. Now press the top green button on the new transmitter once and release.  
*The flashing LED will change to continuous for 1 second each time it accepts a new transmitter.*
5. Repeat step 4 for other transmitters to be added on to the system.
6. Thirty seconds after loading the last transmitter the LED changes to flashing yellow for ten seconds and then returns to normal running mode. Alternatively you can press the top green button of a transmitter that has just been loaded, this will take it straight back to normal running mode.

### Dipswitch Method (Take care when removing lid as it is attached to circuit board)

1. Turn Dipswitch 1, 2 & 3 OFF and 4 ON and then wait 2 seconds.  
The lid-mounted signal LED will give a quick YELLOW flash.
2. Press the open button on the board.  
*The flashing LED will change from flashing YELLOW to flashing GREEN.*
3. Now press the top green button on the new transmitter once and release.  
*The flashing LED will stay on for 1 second each time it accepts a new transmitter.*
4. Repeat step 3 for all other transmitters to be added on to the system.

If you do not select Add mode the unit will time out and flash the signal LED, RED / GREEN. To return to flashing YELLOW press the stop button on the board.

To exit programming mode set dipswitch 4 to **OFF**

## 14

## DELETING TRANSMITTERS

Transmitters can be deleted using the on board Dipswitches or with a transmitter that is already loaded onto the control unit.

**STEEL LINE STRONGLY ADVISE THAT ONLY QUALIFIED INSTALLERS USE THE DIPSWITCH METHOD AND ONLY IN THE EVENT OF THE LOSS OF ALL OTHER TRANSMITTERS**

### Existing Transmitter Method

**Warning:** - This will remove all the existing transmitters from the system except for the one it is carried out with.

1. Press and hold down the Grey button on the existing transmitter.  
*The lid-mounted signal LED will flash YELLOW slowly; keep the button held down until it flashes YELLOW quickly.*
2. Release the Grey Button.  
*The lid-mounted signal LED will continue to flash YELLOW quickly.*
3. Press the stop button on the same transmitter until the following sequence has been carried out  
*The flashing LED will change from flashing YELLOW to a fast flashing RED. After 10 seconds it will turn solid RED, after a further 5 seconds it will turn solid YELLOW and then after a further 2 seconds solid GREEN for 2 seconds.*  
*You must release the stop button when the LED is GREEN.*

All transmitters except the one used to carry out the delete command have now been deleted from the system and it will automatically return to normal running mode.

### Dipswitch Method

**Warning:** - This will remove all the existing transmitters from the system.

1. Turn Dipswitch 1, 2 & 3 OFF and 4 ON, wait 2 seconds.  
*The lid-mounted signal LED will give a quick YELLOW flash.*
2. Press and hold down the stop button on the board until the following sequence has been carried out  
*The flashing LED will change from flashing YELLOW to a fast flashing RED. After 10 seconds it will turn solid RED, after a further 5 seconds it will turn solid YELLOW and then after a further 2 seconds solid GREEN.*

*You must release the stop button when the LED is GREEN.*

All transmitters have now been deleted from the system. The lid-mounted signal LED will flash RED/YELLOW/GREEN repeatedly until Dipswitch 4 is turned OFF.

If you do not select Delete mode the unit will time out and flash the LED, RED / GREEN. To return to flashing YELLOW press the stop button on the board. To exit programming mode set dipswitch 4 to OFF.

## 15 DIP SWITCHES

• There are 2 sets of dipswitches on the Thermaglides remote control, under normal operating conditions ALL SWITCHES SHOULD BE IN THE OFF POSITION

• There are a few instances when the dip switches need to be moved, when using an additional photo cell, deleting hand transmitters and fitting the door when using a generator.

### (DIP 1)

Dip 1 located centre left of the control board.

Number 1:

**ON** = If Using a PEC **OFF** = No PEC

Number 2:

**ON** = Dead Man Open **OFF** = Push To Run Open

Number 3:

**ON** = Dead Man Close **OFF** = Push To Run Close

Number 4:

**ON** = Programming Mode **OFF** = Normal Operating Mode

### (DIP 2)

DIP 2 located top right of the control board.

If a switch is in the 'OFF' position it has no effect to how the board works.

To activate the function push the switch to the 'ON' position

**Number 1:**

Turns off the stall detect feature.

**Number 2:**

Allows the unit to be installed using a generator (**Put back to off when mains is available**)

**Number 3:**

Allows the unit to work with any single-phase motor (**E.g. Somfy Hercules 5-Wire**)

**Number 4:**

Slows down the return time of the door after hitting an obstruction, by stopping the door and then returning in the up direction to free the obstruction.

## 16 MULTI DOOR CONTROL

- It is possible to operate up to 8 Thermaglides from 1 transmitter (see section 13)
- These will come pre coded to the door at point of order, if additional handsets are required we strongly advise contacting Steel-Line doors 01724 270396.
- Supplementary instructions available on request.

## 17 PROBLEM SOLVING

• The section entitled Problem solving has been elevated to 17 as there are no requirements for the sections entitled, Photoelectric cell override, fault diagnostic and safety reverse check.

The Thermaglides Remote Control allows a full fault finding diagnostic to be run, this is all dependant on there been power to the unit.

All of the diagnostics are reported via the Tri coloured LED on the front panel of the unit.

System Status	Problem	Action
fast red/amber/green flashes	fob not learnt i.e. Different manufactures code fob transmission	Contact Steel-Line agent
fast amber flashes	safety edge activation or obstruction	Send Door to fully open position
1 amber 3 red flashes	magnet_tmr expired or safety edge failed to see magnet in close direction	Check magnet still attached to guide rail. If problem continues contact Steel-Line agent.
slow red flashes	pause mode, waiting for ticks to restart door if transmission not received going past top magnet	Send door down.
fast red flashes	PEC "safety" beam broken	Check for obstruction in opening. Check PEC alignment.
1 amber 2 red flashes	self test fail (PEC) if dip1.1 is in the "ON" position	Contact Steel-line agent.
1 red 2 amber flashes	motor stall indication	Check guides and coil for obstruction, remove and operate door as normal.
1 red 3 amber flashes	Motor thermal trip activated or motor not connected. (During install both limits may be open)	Leave door for 20 minutes and retry, if persists contact Steel-Line agent.
1 long red flash 1 short red flash	Emergency stop input open circuit or stop button held pressed. (Check link between T11 & T12)	Contact Steel-Line Agent
2 red/amber/green flashes	on power up or when reset button is pressed	
red/green flash	relay weld (service will be required)	Contact Steel-Line Agent
1 green 2 amber flashes	alarm triggered indication	Press open button on hand set

### Additional Problem solving

Door tight or jams in operation

#### 20.5 DOOR TIGHT OR JAMS IN OPERATION

- Check for good entry of curtain laths into guide rails.
- Check that bottom lath is correctly engaged into track when fully open (see Section 9.1).
- Check for correct clearance of curtain in guide rails. NB: laths should have a sideways 'end float' of approx 6mm.
- Adjust guide rails if necessary to achieve free movement.

#### Poor range on transmitters

- Are the 2 aerials fitted?
- Ensure the aerials are not touching.
- Check batteries in hand set, small LED on hand set will slow flash if battery quality poor.
- Interference from illegal transmissions on 433 frequency.

## 18 OPERATING INSTRUCTIONS

### 18.1 General operation

Your THERMAGLIDE door can be operated from outside or inside the garage using the Remote Control Handset, or from inside the garage using the START BUTTON mounted on the Control Box.

**CAUTION:** Activate unit only when the door is in full view, free of obstructions and operator is properly adjusted. No one should enter or leave the garage while the door is in motion. Do not allow children to play near the door.

### 18.2 In event of power failure

If the door is not used during the power failure then no action has to be taken as the unit will reset itself when the power is restored.

If required the door can be operated manually by using the winding handle supplied, for which you have to gain access to the inside of the garage.

Insert the hooked end of the winding handle into the override eye, this is projecting downwards from the drive motor at one end of the curtain roll.

Insert the hooked end of the winding handle into the override eye, this is projecting downwards from the drive motor at one end of the curtain roll.

(see Section 8). Rotate the handle to operate the door to open or close.

**IMPORTANT** If the garage has no service door then an EXTERIOR RELEASE KIT should have been fitted to allow EMERGENCY opening from outside. Follow instructions supplied with that kit.

**NOTE:** When closing the door manually ensure that the locking joints are set in the fully closed position to ensure security (see Fig. 28).

## 19 MAINTENANCE

The Thermaglide door is essentially a low maintenance product but certain simple checks, carried out regularly, will ensure extended trouble free operation.

### CLEANING

- Periodically wash the door curtain with warm soapy water using a soft cloth.
- Check and clean out the guide rails, removing any accumulated leaves and debris.
- Ensure door closes onto a level clean surface.
- Clean photocell lens and reflector using damp soft cloth.

### SAFETY

Regularly check the **safety reverse** photo beam for correct operation (see Section 19).

## 20 ACCESSORIES

The following accessories are available for use with your THERMAGLIDE door:-

DPIN	806203	Hand Transmitter
DPIN	806204	Wireless Key Pad
DPIN	806205	Photo Cell
DPIN	806206	Bracket and reflector for Photo Cell
DPIN	806208	Battery Back up 350 VA (doors up to 7m2)
DPIN	806209	Battery Back up 500 VA (doors up to 11m2)
DPIN	806210	Battery Back up 650 VA (doors over 11m2)
DPIN	806212	Wall bracket (small) for 350/500 VA battery back up
DPIN	806213	Wall bracket (large) for 650 VA battery back up
AZAT	0003	Up/down switch
AZAT	0004	Touch up paint ALL COLOURS
AZAT	0005	Exterior release kit
* AZAT	0050	Fascia plate WHITE/BROWN/BEIGE cut to your required length.
* AZAT	0051	Vision panel

\*Only available when ordered with door.